

TL150 ..



Spur gear winch

Hand driven spur gear winch:

- robust and safe hoisting winch
- static safety factor of 4
- load pressure brake with double ratchet system
- maintenance-free bearing
- adjustable crank from 250 to 280 mm, ergonomic plastic grip
- cable outlet to left, right, and top side
- standard paint finish 1 layer (60 - 80 Micron), or zinc-plated finish (6 - 8 Micron)
- optional ATEX certified  II 3 GD T3, suitable for zone 2 and 22
type example TL150 GR/Ex
- in compliance with EN 13157 and DIN 15020 and Ex types ATEX 95 (94/9/EG)



Technical specifications TL150 ..

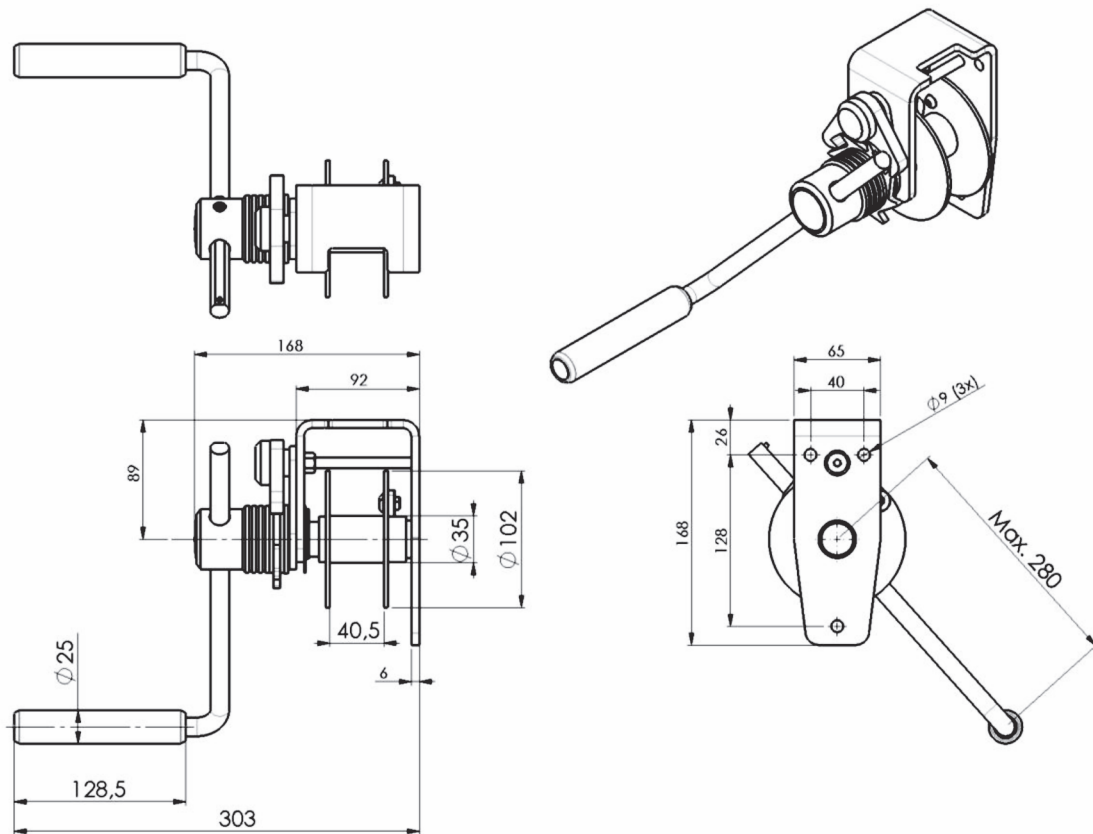

Type	Mounting	Material	Remarks
TL150 GR	Wall, 3x M8 class 8.8	Painted finish	RAL 7035 (grey)
TL150 EV	Wall, 3x M8 class 8.8	Zinc-plated finish	

Technical specifications	TC150
Capacity:	
1 st cable layer	150 kg
Last cable layer	68 kg
Crankforce 1 st cable layer	11 daN
Hoisting length by one rotation of the crank, 1 st layer	122 mm
Cable capacity	13 m
Diameter cable	4 mm
Min. breaking load cable (EN 12383-4)	9 kN
Own weight	4 kg