

## Horizontal directional blocks

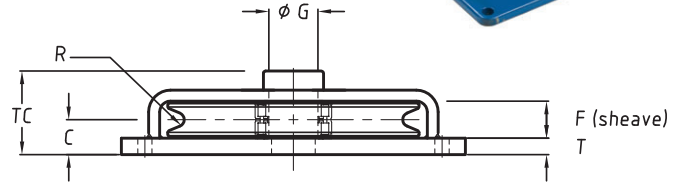

Cylindrical roller bearing

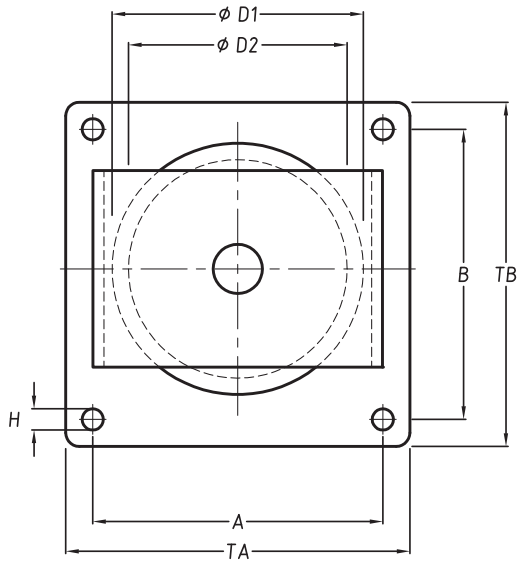
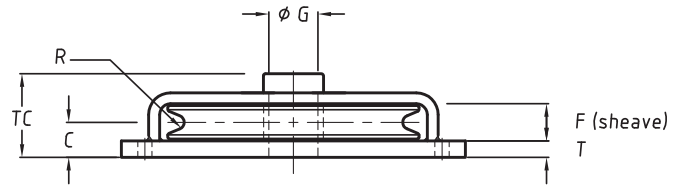

Bronze bushing

### Bronze bushing

Stock No.	WLL (t)	Wire size up to (mm)	Bearing	Dimensions (mm)													Weight (kg)
				$\phi D1$	$\phi D2$	A	B	C	F	$\phi G$	H	T	R	TA	TB	TC	
25.125.01.70	1	10	Bronze	125	105	180	150	22.5	27	22	9	8	5.5	200	170	54	5
25.150.02.70	2	12	Bronze	150	120	220	190	31	40	30	11	10	6.5	250	220	72	10
25.200.03.70	3	14	Bronze	200	165	290	240	33	40	30	13.5	12	7.5	320	270	76	17
25.250.04.70	4	18	Bronze	250	210	360	310	38.5	45	35	17.5	15	9.5	400	350	86	32
25.300.06.70	6	20	Bronze	300	255	400	360	46	50	40	22	20	11	450	410	99	50
25.350.08.70	8	22	Bronze	350	305	460	420	46	50	45	26	20	12	520	480	99	70
25.400.10.70	10	24	Bronze	400	345	530	480	51	60	50	32	20	13	600	550	113	100

Minimum Ultimate Strength = 4 x WLL.

### Ball or cylindrical roller bearing

Stock No.	WLL (t)	Wire size up to (mm)	Bearing	Dimensions (mm)													Weight (kg)
				$\phi D1$	$\phi D2$	A	B	C	F	$\phi G$	H	T	R	TA	TB	TC	
25.125.01.71	1	10	2 x Ball	125	105	180	150	22.5	27	22	9	8	5.5	200	170	54	5
25.150.02.71	2	12	2 x Ball	150	120	220	190	31	40	30	11	10	6.5	250	220	72	10
25.200.03.71	3	14	2 x Ball	200	165	290	240	33	40	30	13.5	12	7.5	320	270	76	17
25.250.04.71	4	18	Straight	250	210	360	310	38.5	45	35	17.5	15	9.5	400	350	86	32
25.300.06.71	6	20	Straight	300	255	400	360	46	50	40	22	20	11	450	410	99	50
25.350.08.71	8	22	Straight	350	305	460	420	46	50	45	26	20	12	520	480	99	70
25.400.10.71	10	24	Straight	400	345	530	480	51	60	50	32	20	13	600	550	113	100

Minimum Ultimate Strength = 4 x WLL.

WLL= Working Load Limit.

- No test certificate possible.
- Groove in sheave may be adjusted to other wire rope diameters.