

# Pressure gauges

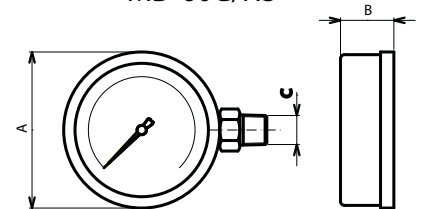

MD-60G/H3



## MD PRESSURE GAUGES

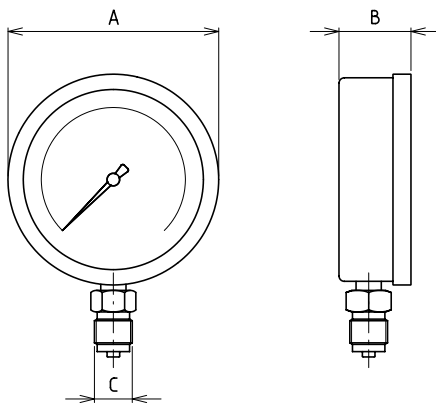

- Glycerine-filled pressure gauges.
- Excellent precision and readability, easy to install.
- Two pressure gauge versions: digital or dual pressure reading scale (bar - ton).

MODEL	PRESSURE range		Ø FACE mm	TYPE	DIMENSIONS in mm		
	Bar	Psi			A	B	C
MD 60 G/H3**	0 - 1000	0 - 14,000	60	GLYCERINE-FILLED	68	28	1/4" NPT
MD 60 G	0 - 1000	0 - 14,000	60	GLYCERINE-FILLED	68	28	1/4" NPT
MD 100 G	0 - 1000	0 - 14,000	100	GLYCERINE-FILLED	110	36	G 1/2" *
MD 100 G/1600	0 - 1600	0 - 23000	100	GLYCERINE-FILLED	110	47	G 1/2"
MD 100 G/2000	0 - 2000	0 - 30000	100	GLYCERINE-FILLED	110	47	G 1/2"
MD 100 G/2500	0 - 2500	0 - 36000	100	GLYCERINE-FILLED	110	47	G 1/2"
MD 150 G/2500	0 - 2500	0 - 36000	150	GLYCERINE-FILLED	160	50	G 1/2"
MD 100 G/4000	0 - 4000	0 - 60000	100	GLYCERINE-FILLED	110	50	M16x1.5
MD 150 G/4000	0 - 4000	0 - 60000	150	GLYCERINE-FILLED	160	50	M16x1.5

\* Swivelling. To properly orient the face.

\*\* Manometer for PMSA3 PUMP