

SD125-250-500..



Swivel Davit



Foldable Swivel Davit:

- robust and safe hoisting Davit
- ready to hoist in only 5 seconds
- covered winch and cable in an ergonomic modern design
- easy to transport, only 25 kg
- 360 degrees rotation over a built in pivot bearing
- maintenance free
- including cable (8m)
- adjustable crank
- paint application in compliance with DIN/ISO 12944, C1M
- integrated winch in compliance with EN 13157, DIN 15020 and EX types ATEX 114 (94/9/EG)
- as option:
 - zinc-plated finish (6-8 Micron)
 - other dimensions on request
 - ATEX certified  II 3 GD T3, suitable for zone 2 and 22

GEBUWIN
metal products



Technical specifications SD125-250-500..

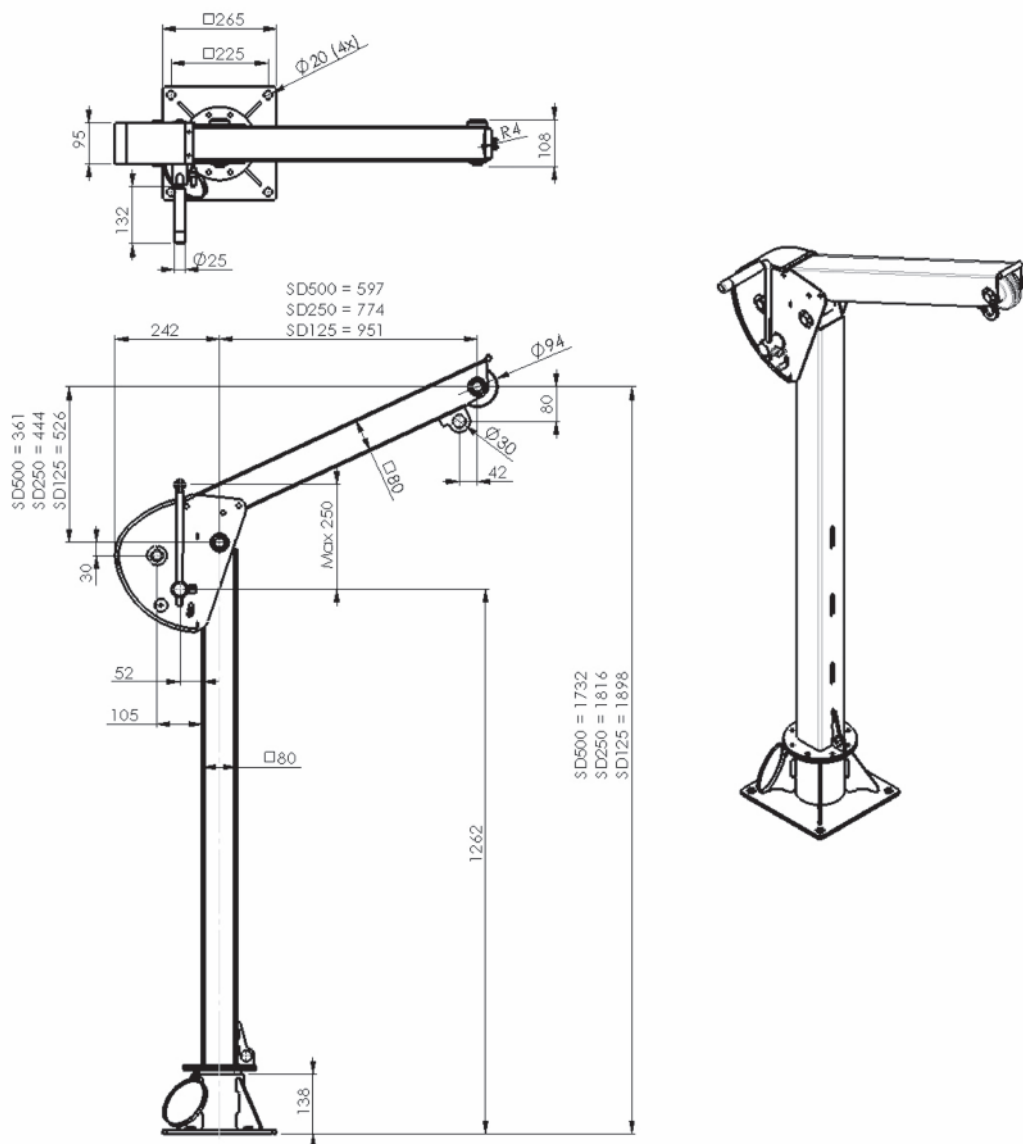

Type	Mounting	Material	Remarks
Swivel Davit SD125, 250, 500 GR	Floor, 4x M18 class 8.8	Painted finish	RAL 7035 (grey)
Swivel Davit SD125, 250, 500 EV	Floor, 4x M18 class 8.8	Zinc-plated finish	
Box Column SD500 EV/ON	On floor	Zinc-plated finish	Including cover

Technical specifications	SD125	SD250	SD500
Capacity:			
1 st cable layer	125 kg	250 kg	500 kg
Last cable layer (7)	125 kg	250 kg	268 kg
Crankforce 1 st cable position	10 daN	10 daN	10 daN
Hoisting length by one rotation of the crank, 1 st layer	20 mm	20 mm	20 mm
Cable capacity	24 m	24 m	13 m
Diameter cable (EN 12383-4)	4 mm	4 mm	5 mm
Min. breaking load cable	9 kN	9 kN	15 kN
Own weight Swifel Davit (cable included)	25 kg	25 kg	25 kg
Own weight box column	7 kg	7 kg	7 kg